

Chapter 89

DOWNTOWN CORE DESIGN STANDARDS

FOR

Township of Derry, Dauphin County Pa.

Adopted March 28, 2017

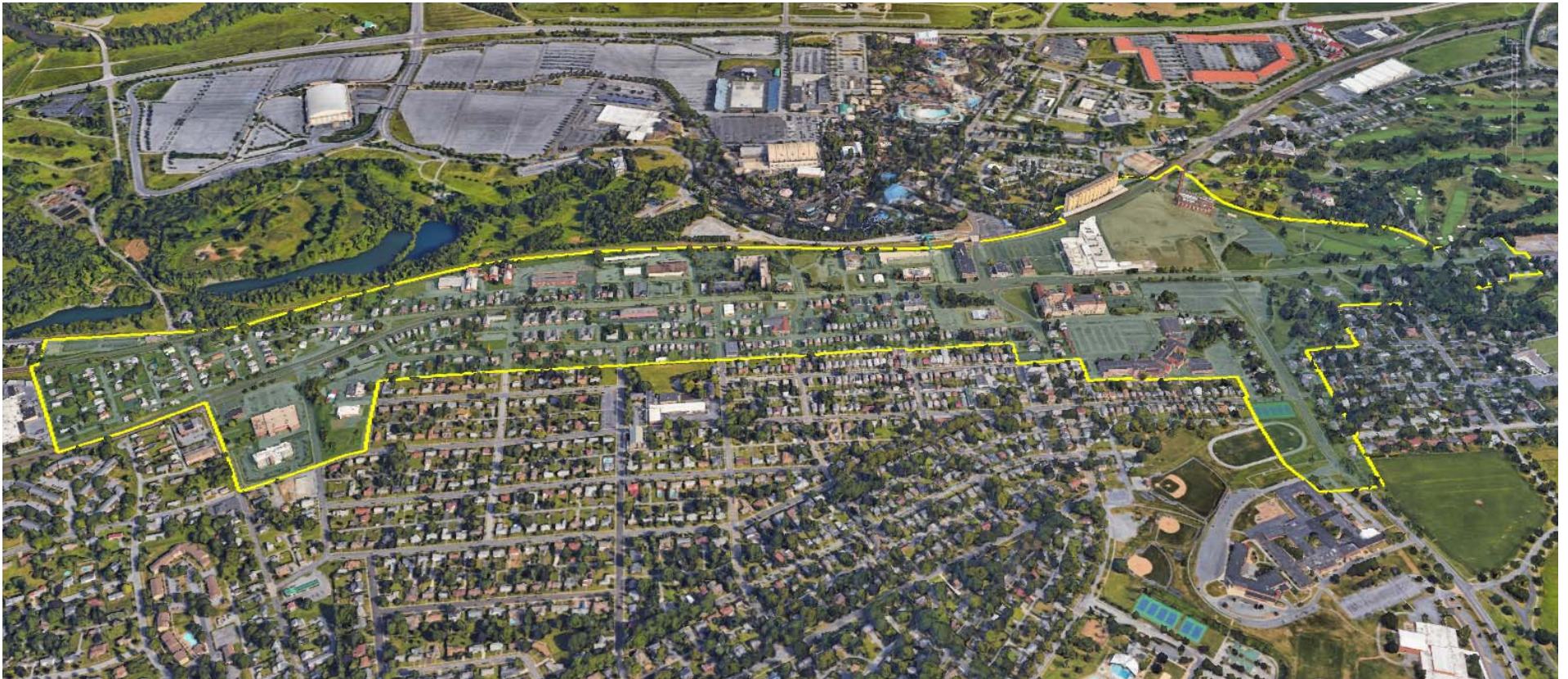

ORDINANCE NO. 686

AN ORDINANCE AMENDING THE CODE OF THE TOWNSHIP OF DERRY, DAUPHIN COUNTY, PENNSYLVANIA, BY ADDING CHAPTER 89 ENTITLED "DOWNTOWN CORE DESIGN STANDARDS"; PROVIDING FOR PURPOSE, INTERPRETATION, APPLICABILITY, AND DEFINITIONS OF THE CHAPTER; ESTABLISHING THE DOWNTOWN CORE DESIGN BOARD (DCDB); PROVIDING FOR REVIEW AND APPEAL PROCEDURES OF THE DCDB; ESTABLISHING APPLICATION SUBMITTAL REQUIREMENTS FOR REVIEW BY THE DCDB; ESTABLISHING DESIGN STANDARDS FOR BUILDINGS, SIGNS, AWNINGS, AND ASSOCIATED PUBLIC AND PRIVATE SITE IMPROVEMENTS WITHIN THE DOWNTOWN CORE OVERLAY DISTRICT; AND PROVIDING FOR PROCEDURES RELATED TO MODIFICATION REQUESTS FROM THE REQUIREMENTS OF THE CHAPTER

WHEREAS, the 2015 Comprehensive Plan, adopted on January 26, 2016, recommends that regulations be provided for mixed land uses and Traditional Neighborhood Developments (TNDs) in accordance with the requirements of the Pennsylvania Municipalities Planning Code (the MPC), as amended; including design standards that establish a list of desirable building materials and design elements that are consistent with the predominant architecture of the Downtown, that provide for harmonious relationships between building massing and scale, that establish regulations for improvements to the Downtown streetscape, and that provide for sufficient regulation of signage and lighting techniques within the Downtown; and

WHEREAS, the Township Zoning Ordinance, intending to be adopted on March 28, 2017, establishes the boundaries of the Downtown Core Overlay District, which are depicted on the Official Zoning Overlay Map, and also identifies a list of permitted uses, densities, and setbacks for the Overlay District, as well as specific design requirements for buildings, parking, landscaping, and signage within the Overlay District; and

WHEREAS, Article VII-A of the MPC authorizes municipalities to establish TND regulations, where such development is consistent with the goals and the objectives of the Township Comprehensive Plan and where the Township Zoning Ordinance establishes a district or districts where all standards, conditions and regulations related to the TND development would be applicable; and

WHEREAS, Article VII-A, Section 708-A of the MPC authorizes municipalities that have adopted provisions for TNDs to also adopt a manual of written and graphic design guidelines for said development upon review and recommendation of the Township Planning Commission; and

WHEREAS, Chapter 89 of the Code of the Township of Derry is intended to serve as said manual of written and graphic design guidelines authorized by Section 708-A of the MPC, to supplement the requirements of the Township Zoning Ordinance by creating additional required design criteria for the Downtown Core Overlay District, and to establish a procedure by which development activities are proposed within the boundaries of the Overlay

District and by which the development activities are reviewed and approved by the Township; and

WHEREAS, pursuant to Article VII-A, Section 708-A of the MPC, a copy of this Ordinance and Chapter has been forwarded to the Township of Derry Planning Commission for review and comment at a public meeting held on March 7, 2017, and the Township Planning Commission issued its recommendations to the Township of Derry Board of Supervisors for their consideration.

NOW, THEREFORE, it is hereby enacted and ordained by the Board of Supervisors of the Township of Derry, Dauphin County, Pennsylvania, as follows:

SECTION 1: Chapter 89 is hereby added to the Code of the Township of Derry to read as follows:

**CHAPTER 89
DOWNTOWN CORE DESIGN STANDARDS**

**ARTICLE I
General Provisions**

§89-1. Title.

This Chapter shall be known and may be cited as the “**Downtown Core Design Standards.**”

§89-2. Purpose and community development objectives.

Pursuant to the authority granted by Article VII-A of the Pennsylvania Municipalities Planning Code, Act 247 of 1968 (the MPC), this Chapter is created for the following purposes:

- A. To protect the existing traditional neighborhood development patterns of the Hershey Mixed Use zoning district in areas where the Downtown Core Overlay district exists, as established pursuant to Section 225-302 of the Township Zoning Ordinance;
- B. To establish design criteria for demolition and new development within the Downtown Core Overlay district, whether it be an outgrowth or extension of existing development; infill development where proposed uses and structures may be incorporated into the existing development fabric of the Downtown; or alterations and additions to existing development, including alterations to private site elements such as signs and awnings, walls and fences, utilities, accessory buildings and structures, and similar site features.
- C. To achieve the purposes and objectives expressly indicated in Section 701-A of the MPC, including the following (in part):

- (1) To encourage innovations in residential and nonresidential development and renewal which makes use of a mixed-use form of development so that the growing demand for housing and other development may be met by greater variety in type, design, and layout of dwellings and other buildings and structures;
 - (2) To extend greater opportunities for better housing, recreation, and access to goods, services, and employment opportunities to all citizens of the Township and surrounding regions;
 - (3) To allow for the development of fully integrated, mixed-use pedestrian-oriented neighborhoods; and
 - (4) To provide for a procedure, in aid of these purposes, which can relate the type, design, and layout of residential and nonresidential development to the particular site and the particular demand for housing existing at the time of development in a manner consistent with the preservation of the property values within existing residential and nonresidential areas.
- D. To promote the implementation of the goals and objectives of the Derry Township Comprehensive Plan entitled “2015 Comprehensive Plan”, adopted by the Board of Supervisors on January 26, 2016.
- E. To promote and facilitate the public health, safety, morals, and general welfare of the Township by encouraging coordinated and practical community development at proper densities and design that provide for adequate light and air, vehicle parking and loading spaces, recreational facilities, and public uses.

§89-3. Interpretation.

In interpreting and applying this Chapter, the following considerations shall be made:

- A. The Downtown Core Design Board (DCDB) is hereby created as the advisory agency responsible for reviewing and making Recommendations of Appropriateness to the Board of Supervisors for construction activities within the Downtown Core Overlay district.
- B. The provisions of each of the design criteria established by this Chapter shall be held to be the minimum requirements to meet the policy, goals, and community development objectives as referenced herein. Any basis for issuing a recommendation of appropriateness shall be based on the determination on whether the applicant has met the minimum design criteria, or has requested the appropriate modifications in accordance with this Chapter.
- C. The design criteria established by this Chapter are in addition to the Downtown Core Overlay criteria established in §225-401.1.l of Chapter 225, Zoning, of the Code of the Township of Derry.
- D. Any use permitted subject to the regulations prescribed by the provisions of Chapter 225, Zoning, shall conform with all regulations for the zoning district in which it is located

and all other pertinent regulations of this Chapter, and other related ordinances of the Code of the Township of Derry.

- E. This Chapter is not intended to interfere with, abrogate, annul, supersede, or cancel any easements, covenants, restrictions, or reservations contained in deeds or other agreements, but if this Chapter imposes more stringent restrictions upon the use of buildings and land than are elsewhere established, the provisions of this Chapter shall prevail.
- F. In interpreting the language of this Chapter, to determine the extent of the influence upon the use of the property, the language shall be interpreted, where doubt exists as to the intended meaning of the language adopted by the Board of Supervisors, in favor of the property owner and against any implied extension of the restriction.

§89-4. Applicability.

No building, structure, or land shall hereafter be used or occupied and no building or structure or part thereof shall hereafter be erected, constructed, reconstructed, moved, altered, or expanded horizontally or vertically within the Downtown Core Overlay, except as approved by either the Downtown Core Design Board and/or the Township Board of Supervisors, as required herein. Compliance with any and all of the conditions imposed by said approval shall be a condition of zoning permit approval for the construction activities proposed. Violations of the imposed conditions shall be considered a violation of Chapter 225, Zoning, and shall be subject to the administration and enforcement procedures of Article X of Chapter 225, Zoning.

§89-5. Repealer.

Any ordinance provision(s) or regulation of the Township inconsistent with any of the provisions of this Chapter is hereby repealed to the extent of the inconsistency only.

§89-6. Severability.

In the event that any section or provision of this Chapter is declared invalid by a court of competent jurisdiction, such decision shall not affect the validity of any of the remaining provisions of this Chapter.

**ARTICLE II
Definitions**

§89-7. Definitions.

- A. Words in the present tense also imply the future tense.
- B. The singular includes the plural.
- C. The male gender includes the female gender.

- D. The term "shall" or "must" is always mandatory.
- E. The words "used" and "occupied" shall be construed to include the words "or intended, arranged, or designed to be used or to be occupied, or offered for occupancy."
- F. The term "such as" shall be considered as introducing a typical or illustrative designation of items, and shall not be interpreted as constituting a complete list.
- G. The word "owner" shall be deemed to include a corporation, unincorporated association and a partnership or other legal entity, as well as an individual.
- H. The words "building" and "structure" shall be construed as if followed by the phrase "or part thereof."
- I. If a term is undefined by this Chapter but is defined in Chapter 225, Zoning, or Chapter 185, Subdivision and Land Development, then the definition of the term in Chapter 225 or Chapter 185 shall also apply to the term used in this Chapter.
- J. If a term is defined in this Chapter and is defined differently in other Chapters of the Code of the Township of Derry, the definition of the term as stated in this Chapter shall apply.

ADJACENT – Within 40' of a feature (unless another distance is specifically defined within the criteria of this Chapter) that is on the same lot, or on an adjoining lot that is not separated from another feature by a public road, including alleys.

DCDB – The “Downtown Core Design Board” as established in this Chapter.

DOWNTOWN CORE OVERLAY – An overlay of the Hershey Mixed Use zoning district as established by Chapter 225, Zoning. This Overlay reinforces compatibility of established and new development character through the retention of a quality environment as a key ingredient in successful revitalization of this area.

MASTER PLAN – A plan or plans and supporting data required by §225-501.58 (Approval Process), of Chapter 225, Zoning, to promote and encourage ingenuity in the layout and design of coordinated projects.

MPC – The Pennsylvania Municipalities Planning Code.

ONE AND TWO FAMILY DWELLINGS – For the purposes of this Chapter, one and two family dwellings shall include single-family detached dwellings, single-family attached dwellings, single-family semidetached dwellings, and two-family dwellings as defined by Chapter 225, Zoning. This shall not include institutional dwelling units, multi-family apartment dwellings, specialty homes, boarding homes, bed-and-breakfast homes, or mixed-use buildings, as such terms are defined in Chapter 225, Zoning.

OVERLAY (ZONING OVERLAY) – The area designated as such on the Official Zoning Maps or as otherwise noted in Chapter 225, Zoning, where provisions that may be more and/or less

restrictive than the base zoning district requirements for the applicable lot or portion thereof may exist.

PRIVATE REALM – Any area located outside of the public right-of-way on private property.

PUBLIC REALM – Any area located within a public right-of-way or easement.

STREETSCAPE FURNITURE – Manmade, above-ground objects including, but not limited to, pedestrian and vehicular safety devices, mass transit stops, mail boxes, public seating, information boards, kiosks, signs, water fountains, waste and litter containers, and similar features.

ARTICLE III Establishment of Downtown Core Design Board (DCDB)

§89-8. Board composition and review procedure.

- A. Membership of the Downtown Core Design Board (DCDB) shall be as follows:
 - (1) Two members of the Derry Township Board of Supervisors serving on the Downtown Hershey Association Board of Directors.
 - (2) Five members appointed by the Board of Supervisors from nominations by the Downtown Hershey Association.
 - (3) In addition to the above voting members, the Board of Supervisors may appoint one or more non-voting members to provide technical oversight to the Board.
- B. The terms of voting members appointed shall be for five years, and shall be so fixed that the term of no more than two members shall expire each year. An appointment to fill a vacancy shall be only for the unexpired portion of the term.
- C. The DCDB shall review proposals which meet the criteria hereinafter required to be reviewed in accordance with the following procedures:
 - (1) The DCDB shall meet monthly, unless there are no applications or businesses to be reviewed by the DCDB.
 - (2) Applications for matters to be considered by the DCDB shall be submitted to the Township and contain all required information pursuant to §89-11 of this Chapter at least 14 days prior to the DCDB meeting at which consideration is desired.
 - (3) The DCDB shall issue a recommendation to the Board of Supervisors, as determined by a majority vote, within 5 business days of the meeting at which the project is considered, with a concurrent copy being provided to the applicant, unless the applicant grants an extension of time in which to act.

- (4) If the DCDB's recommendation is accepted by the written agreement of the Applicant, the Department of Community Development may issue a permit or give authorization to commence such work. (See §89-10.D for activities that require Board of Supervisors approval prior to issuance of a permit to commence proposed activities).
- (5) If the Applicant does not grant written agreement of acceptance of the DCDB's recommendation within 5 business days of the date of the recommendation, the Board of Supervisors shall consider the recommendation at a public meeting within 20 business days of receipt thereof, notice of which shall be given to the applicant, at which time the applicant may raise objections to the DCDB's recommendations. The Board of Supervisors shall make a decision at that same public meeting, unless the applicant grants an extension of time in which to act.

D. Applicants submitting Master Plans under the requirements of §225-501.58 of Chapter 225, Zoning, shall have the plans reviewed by the DCDB in accordance with the procedures of §89-8.C prior to filing a conditional use application with the Township.

§89-9. Appeals from recommendations of the DCDB.

Any applicant aggrieved by the DCDB's recommendation, or from the conditions provided therein, will receive an automatic appeal to the Derry Township Board of Supervisors, pursuant to the procedure set forth in §89-8.C.(5). An applicant's failure to appear at the public meeting, after receiving notice that the matter will be considered, may result in an automatic denial of the application and acceptance by the Board of Supervisors of the recommendation of the DCDB.

§89-10. Activities to be reviewed.

- A. Except as exempted by §89-10.A.(5), the following activities shall be subject to review under this Chapter:
 - (1) Any sign or awning which is erected, placed, or altered within the Downtown Core Overlay district.
 - (2) Any murals and other public art within the Downtown Core Overlay district.
 - (3) Buildings and outdoor improvements located within the Downtown Core Overlay district which are outside the public right-of-way, including:
 - (a) Any material change in the exterior appearance of existing buildings or structures.
 - (b) Any new construction of a principal building, principal structure, accessory building, or accessory structure.
 - (c) Any material change of existing walls, fences, driveways, and parking areas or construction of new walls, fences, driveways, and parking areas.

- (d) Any addition or alteration of any type of exterior lighting device.
 - (e) Partial demolition of existing buildings or structures comprising less than 50% of the visible area of the building or structure.
 - (f) Demolition of existing buildings or structures comprising 50% or more of the visible area of the building or structure.
- (4) The Board of Supervisors shall have sole approval authority for all proposals for activities specified in §89-10.A.(3).(b) and §89-10.A.(3).(f). The Board of Supervisors shall consider the recommendation of the DCDB, as well as testimony offered by the applicant, at a public meeting of the Board of Supervisors within 20 business days of receipt of the DCDB's Recommendation of Appropriateness, notice of which shall be given to the applicant. The Board of Supervisors shall make a decision at that same public meeting, unless the applicant grants an extension of time in which to act.
- (5) The following activities shall be exempted from review under this Chapter:
- (a) Ordinary maintenance and repair to existing buildings and structures that will result in no material change to the façade appearance.
 - (b) Color and message changes to existing signs where no other alterations are proposed in accordance with the definitions of Chapter 225, Zoning, and provided that all signs that contain the dimensional relief required by §89-13.A.(3) maintain the relief with the color or message change to the sign.
 - (c) Erection of any sign exempted from permit requirements under Section 225-401.4.C of Chapter 225, Zoning.
 - (d) All vegetative landscaping and buffering complying with Chapter 225, Zoning, and Chapter 185, Subdivision and Land Development, as applicable.
 - (e) The following activities on properties that contain no frontage along Chocolate Avenue:
 - [1] Any new construction of a principal building, principal structure, accessory building, or accessory structure on properties used for one and two family dwellings only.
 - [2] Any material change of existing walls, fences, driveways, and parking areas or construction of new walls, fences, driveways, and parking areas on properties used for one and two family dwellings only.
 - [3] Any material change in the exterior appearance of existing buildings or structures on properties used for one and two family dwellings only.
 - [4] Any addition or alteration of any type of exterior lighting device on buildings or structures used for one and two family dwellings only.

- [5] Demolition of existing principal buildings, principal structures, accessory buildings, or accessory structures, or portions thereof, used for one and two family dwellings only.

§89-11. Minimum data required for review.

- A. A narrative providing explanation of the proposed project and how the purpose and objective statements and minimum design criteria of §89-12; §89-13 and §89-14 have been addressed in the building design, sign or canopy design, or design of private site elements, as may be applicable to the project proposal.
- B. Proposed signs or proposed alterations to existing signs shall be accurately depicted on drawings which designate the height, width, depth, colors, materials, message, lighting source, and exact location of the proposed signs or sign alterations.
- C. A site plan shall be required for any improvements deemed to be of such significance by the Director of Community Development that a site plan will be necessary in order for the DCDB to conduct a thorough review of the proposal. Site plans may be required for outdoor improvements, new buildings, and additions to existing buildings, but shall not be required for projects that are changing only the exterior materials or appearance to existing buildings with no other site layout changes proposed. When a site plan is required, the following minimum information shall be depicted on the plans:
 - (1) All lot lines, minimum yard area lines, and lines of existing streets and rights-of-way.
 - (2) All existing or proposed improvements on the lot including, but not limited to, buildings, structures, parking areas, curbs, sidewalks, lighting devices, and landscaped areas.
- D. Interior floor plans are required for all new buildings.
- E. Exterior elevations shall be submitted for material and appearance changes to existing buildings in such detail that the Board can fully envision the completed alteration, with the full knowledge of colors, materials, window sizes, etc.
- F. A list of any modifications being requested from the design standards of this Chapter pursuant to the requirements of §89-15.
- G. For submittals of buildings within a Master Plan subject to §225-501.58 of Chapter 225, Zoning, the applicant shall file a site development plan, a landscaping plan, signage plans, and the architectural and design standards for the development, including the illustrative building types, elevations, and the siting and cross section renderings of proposed buildings showing compliance with the Master Plan requirements. All plans and supporting information shall contain the information required by §225-501.58 of Chapter 225, Zoning.

- H. Samples and specification sheets of the materials, fixtures, and finishes being used in the development activity shall be provided with the application. Other photographs and renderings of similar existing development, whether located within or outside of the Township, may also be submitted to demonstrate the final conditions of the proposed activity.
- I. The fee for review by the DCDB shall be in an amount as established from time to time by resolution of the Board of Supervisors.

ARTICLE IV
Downtown Core Overlay Design Standards

§89-12. Design standards for buildings.

The following standards apply to new development, redevelopment, and alterations in the Downtown Core Overlay. As a result, the standards address issues related to retention of existing buildings that will be altered and/or expanded; as well as new building construction that will infill undeveloped land areas; or demolition and redevelopment of existing sites in the Downtown Core Overlay. A general observation of these design standards is that all buildings in the Downtown should relate to and respect the continuity and character of existing block fronts and adjacent buildings that are such a strong determinant of the character of the Overlay. The goal is to maintain quality, character, and spatial continuity. The following standards address the minimum considerations for the design of newly developed, expanded, or altered buildings in the Downtown Core Overlay:

- A. Demolition of existing buildings. Adaptive reuse of existing buildings shall be utilized to the greatest extent possible. In the event that demolition of an existing building is proposed, the applicant shall submit the following relevant information on the structure in order to demonstrate the infeasibility of adaptive reuse:
 - (1) That the structural integrity of the building is beyond repair or reuse and as a result, the demolition of the existing building is in the best interest of public safety and welfare. The applicant shall provide a structural engineer's report to demonstrate structural disrepair.
 - (2) That the desired general aesthetics and compatibility of design with surrounding uses will be more achievable with demolition of the existing structure and construction of a new building.
 - (3) That the safety of vehicular and/or pedestrian access to the building will be more achievable with construction of a new building.
- B. Building materials, textures, and color. Buildings shall contain a harmonious variety of materials and textures in order to provide visual interest and a unique downtown setting in the Overlay. The selection of materials and textures for a new building shall be compatible with and complement adjacent buildings. The use of material elements from the existing architectural detailing of the buildings in Downtown (see Appendix A) shall

be encouraged. Entire façades need not contain these elements; however, proposed designs shall be compatible with these features. The following minimum criteria shall be applicable to achieve this objective:

- (1) Ground floors of buildings shall not contain blank façade walls along street fronting sides of the building. (A variety of design elements that create visual interest and distinguish the ground floors from the floors above shall be provided. This may include a combination of features such as articulated building entrances, covered porches, building cornices, window treatments and awnings, building accent lighting, or other similar decorative façade features.)
- (2) The following building materials shall be permitted within the Downtown Core Overlay:
 - (a) Brick, in red color ranges and constructed in traditional bond patterns with a joint finish that is complementary to adjacent buildings.
 - (b) Natural stone materials (native sources) constructed in ashlar and traditional bond patterns and complementary to adjacent buildings.
 - (c) Fiber cement siding.
 - (d) Exterior Insulation and Finish Systems (EIFS) when used as accent materials to the items listed in §89-12.B.(2).(a), (b), and (c), or when embellished to resemble the brick or stone patterns of the items listed in §89-12.B.(2).(a) and (b), and upon approval of the DCDB or the Board of Supervisors, as appropriate.
- (3) The following roofing materials shall be permitted within the Downtown Core Overlay:
 - (a) Asphalt shingles (three-tab or architectural).
 - (b) Standing seam metal.
- (4) Building material colors shall be coordinated in order to comply with one of the following color palettes:
 - (a) The National Trust for Historic Preservation's collection of historic colors, as amended.
 - (b) Benjamin Moore's Williamsburg Collection.
 - (c) Sherwin-Williams America's Heritage Collection.
- (5) Building glass shall be constructed to no more than a 50% opacity on ground floor levels. Non-tinted glass is preferred.

- C. Building form and orientation. New buildings, as well as street-fronting additions to existing buildings, should be constructed so that setback relationships with the street are consistent with adjacent buildings. Existing buildings that contain greater setbacks from the street than those adjacent buildings are encouraged to provide for elements that occupy the voids between the building setbacks and the public realm. These elements may include porches, patios, and seating elements, or a combination of landscaping or masonry walls that maintain the visual sight lines of the neighborhood block. New development should also consider multi-use spaces in order to diversify the land uses of the Downtown Core Overlay and create a compact urban form that is traditional to a downtown setting. Lastly, the massing of new buildings (the relationship of a building's width to its height) should be similar to, and compatible with, existing adjacent buildings along the street. The following minimum criteria are required to establish these objectives:
- (1) All buildings fronting along Chocolate Avenue shall be oriented toward the public street with pedestrian access occurring from the public sidewalk.
 - (2) All new buildings constructed in the Downtown Core Overlay shall be a minimum of two-stories, or shall contain a minimum height of 35 feet when located along Chocolate Avenue.
 - (3) New buildings or expansions to existing buildings that will contain a street facing façade wall greater than 50 feet in width shall be articulated so that the major elements of the façade reflect the width and proportion of the adjacent buildings.
 - (4) Articulation may be achieved by vertically off-setting façade walls a minimum of 16 inches every 50 feet, or by constructing horizontal protrusions or insets from the building that may include such features as balconies, cornices, or awnings.

§89-13. Design standards for signs and awnings.

Commercial signs are a vital part of the Downtown Core Overlay scene. A balance must be struck between the need to identify and call attention to individual businesses and the broader need for a positive identity and image of the entire corridor. Signs should not be a detraction in the downtown; they should enhance it. Excessive competition for visibility and an overemphasis on being seen from passing vehicles have all too often resulted in a shopping environment characterized by visual clutter with oversized, poorly placed, and badly designed signs. Awnings, too, can either add to or detract from the character of downtown, depending on the care and attention given to their use. The goal is to insure that the use of signs and awnings not only adds to the overall image of downtown, but also enhances the buildings and storefronts of which they are a part, all while promoting the uses.

- A. Design of signs. Sign location should enhance the pedestrian-oriented character of the Downtown Core Overlay. As such, signage should be placed in a manner that helps to define the primary entrance to the building. Projecting signs are encouraged to support the traditional aesthetics and pedestrian scale of commercial spaces in the downtown. The following minimum criteria shall be required to achieve this objective:

- (1) All signs shall comply with the requirements for the Downtown Commercial Sign Overlay of §225-401.4.F.C of Chapter 225, Zoning.
- (2) Sign design and graphics shall be coordinated with the character of the building, as well as the nature of the business, and should be of a professional design quality.
- (3) Dimensional signs shall be utilized. Sign messages done in relief shall be raised at least ¼ inch off of the sign face and carved signs shall have a depth of at least ¼ inch. Messages containing lettering or font sizes that are one inch or less are not required to meet the dimensional criteria.
- (4) Signs shall be indirectly illuminated with light sources attached to the building or sign support structure, or mounted on the ground, depending on the type of sign to be illuminated. The light shall be cast downward or upward onto the sign. Halo-illuminated signs are also appropriate for the Downtown Core Overlay.

B. Design of awnings. The use of awnings is encouraged, as they often serve multiple purposes in a downtown, including improving the aesthetics of existing buildings, providing defined building entrances, providing continuity of sight lines along a block front, offering weather protection to pedestrians and building structures, and encouraging energy efficiency by shading window and door openings. The following minimum design criteria shall be required to achieve this objective:

- (1) Awnings shall be constructed of fabric, metal, or glass material.
- (2) Awnings shall be monochromatic or contain striping with no more than two colors, exclusive of black and white.
- (3) Illumination of awnings shall only be permitted in accordance with §225-421 of Chapter 225, Zoning.
- (4) All awnings must be maintained in a clean, untattered, unbroken, and rust-free condition.

§89-14. Design standards for public and private realm improvements.

The relationship between existing and new buildings along a corridor and the private site features within a property's boundary helps to define its character and should be considered an important part of the review of any project. Thoughtful and careful planning of public realm improvements, such as streetscape furniture, sidewalks, and public art pieces, and private realm improvements, including parking facilities, fences, walls, utility and sanitation structures, and accessory buildings, are all required in the Downtown Core Overlay to ensure adequate connections between both realms and to provide complementary designs between all features. Private realm improvements are generally associated with private responsibilities and involve a concern with retaining, preserving, and maintaining existing elements, as well as the creation of new elements within a given site. All of the following criteria apply to both improvements and modifications related to rehabilitation projects and new construction. All site improvements and modifications should be compatible with the character of existing surrounding sites with the purpose of contributing to the continuity of the

character that has been achieved in a given corridor. All site elements should relate in regard to individual features, materials, and their arrangement so as to provide continuity along the street and to enhance the building on the site. As such, the following minimum criteria shall be required for all public and private realm improvements to achieve these objectives:

A. Public realm improvements.

- (1) All streetscape furniture placed in the public right-of-way, including benches, trash receptacles, bicycle racks, planters, and lighted bollards, but excluding seasonal outdoor seating offered by private landowners, shall be of the Downtown Standard as referenced in Appendix B of this Chapter. Similar elements placed outside of the public right-of-way, including seasonal outdoor seating, shall not be required to meet Appendix B; however, such elements shall complement the character of nearby public streetscape furniture and existing or proposed building materials and color schemes.
- (2) Public sidewalks and walkways that are constructed as part of new building projects requiring a land development plan under Chapter 185, Subdivision and Land Development, shall be constructed to a minimum width of 8 feet and shall be maintained on all public street frontages. Materials and specifications of public sidewalks constructed in the Downtown Core Overlay shall meet the requirements of Appendix B.
- (3) Murals and street art shall be permitted in accordance with §225-501.56 of Chapter 225, Zoning.

B. Outdoor seating in the private realm.

- (1) Seasonal outdoor seating is encouraged in the Downtown Core Overlay. The design shall be consistent with the materials and color of the principal building or the character of nearby public streetscape furniture.
- (2) Outdoor seating or similar streetscape furniture that will encroach onto public sidewalks shall maintain clearance distances specified in accordance with §89-14.C.(3).

C. Pedestrian connections between the public and private realms.

- (1) Private on-site sidewalks and walkways to and from the property shall connect to all public spaces and public sidewalks that provide access to the building. Connections to adjacent properties shall be made, where feasible, in order to provide an interconnected network of pedestrian access throughout the Downtown Core Overlay.
- (2) Private sidewalks, walkways, stairs, patios, and plazas shall be constructed of concrete, brick in red color ranges, or natural stone pavers.

- (3) A minimum clearance of 5 feet shall be maintained on all public sidewalks fronting along Chocolate Avenue, and 4 feet along all other street frontages around any outdoor seating elements that will encroach into the right-of-way.
- (4) Construction activities proposed on development areas totaling 2.5 acres or more shall provide public plazas, green spaces, or parks, or a combination thereof, as part of the project. Spaces devoted to these uses shall be a minimum of 2,500 square feet. The public spaces do not need to be provided in a contiguous manner but shall be well connected to promote public gathering and use of adjacent amenities and commerce.

D. Parking areas and driveways.

- (1) Location of parking spaces and associated landscaping shall be provided in accordance with §225-401.1.I of Chapter 225, Zoning.
- (2) Shared parking in compliance with §225-402.4 of Chapter 225, Zoning, shall be provided when possible in order to avoid unnecessary impervious cover and encourage pedestrian connectivity between properties.
- (3) Access to parking facilities, including all deck parking structures, shall be provided by driveways from alleys or secondary streets rather than providing direct access onto Chocolate Avenue.
- (4) When fronting along Chocolate Avenue, deck parking structures shall comply with the following requirements:
 - (a) Design and construction materials shall comply with the building material requirements of §89-12.B.(2) of this Chapter and shall be consistent with the architectural styling and materials of adjacent buildings.
 - (b) Commercial uses or faux façades that maintain the appearance of a continuation of the adjacent building massing shall be constructed along the ground floor of the structure to maintain the traditional character of the downtown setting.
- (5) Deck parking structures that are setback 20 feet or more from the right-of-way of Chocolate Avenue shall comply with the building material requirements of §89-12.B.(2) of this Chapter, or shall consist of patterned concrete material subject to approval by the DCDB.

E. Fences.

- (1) Fences shall comply with §225-407.B of Chapter 225, Zoning, in addition to the criteria of this Chapter.
- (2) Fences shall be made of iron, aluminum, wood, or natural vegetative hedgerows when placed parallel to and visible from Chocolate Avenue and where existing fences on adjacent properties contain these same elements and are in good

condition. Any continuation of fencing shall contain the same finish as the existing fence to maintain a seamless transition between elements. All other fencing shall consist of the following materials:

- (a) Finished wood with void spaces.
- (b) Finished metal (non-woven).
- (c) Vinyl.
- (d) Vinyl-coated, chain-link fencing in accordance with §225-407.B of Chapter 225, Zoning.

(3) Maintenance and repair of existing fences that are compatible with predominant building materials on the property and/or adjacent properties is important and shall be carried out to the greatest extent possible in lieu of removal or replacement.

F. Masonry walls and rails.

(1) All masonry walls shall be constructed of the following materials, with color the palette being compatible with that of the principal building on the property:

- (a) Natural stone (mortared, dry-stacked, or veneer).
- (b) Brick (mortared or veneer).
- (c) Stucco.

(2) Maintenance and repair of existing walls that are compatible with predominant building materials on the property and/or adjacent properties is important and shall be carried out to the greatest extent possible in lieu of removal or replacement.

(3) The street-facing side of masonry walls proposed within 10 feet of a street right-of-way line (excluding alleys) shall not exceed 42 inches in height (excluding guards or handrails), unless the adjacent ground elevation would necessitate a higher retaining wall to be constructed.

(4) Railing installed on top of masonry walls or handrails erected along sidewalks shall be made of a finished metal or wood material.

G. Lighting. Lighting shall comply with the requirements of Chapter 225, Zoning, and Chapter 185, Subdivision and Land Development, as may be applicable to the construction activities proposed. Specifications on lighting fixtures and illumination levels shall be provided with a submission to the DCDB.

H. Utilities and dumpster pads.

(1) All new utilities and equipment shall be placed underground or in the basement (or other lower ground levels) of the building.

- (2) When overhead and exterior wires, utility poles, utility equipment, or antennas are required, the structures shall be placed to the rear of the buildings and, when possible, shall be screened with evergreen hedgerows or fences and walls that meet the criteria of this Chapter.
- (3) Roof-mounted structures shall favor the non-street fronting side of the building, be screened from view with parapet walls, or shall be otherwise integrated into the building façade.
- (4) Dumpster pads shall be located to the rear of building and shall be shared by multiple users to the greatest extent possible. Pad locations shall be screened by evergreen hedgerows or by masonry walls made of materials that meet the criteria of §89-14.F.(1). Finished wood materials shall also be permitted to screen dumpster pads.

I. Accessory buildings and structures.

- (1) Accessory buildings and structures such as garages, sheds, and carports shall not be located between the street right-of-way and the front façade of the principal building on the lot.
- (2) Vinyl siding shall be permitted on accessory buildings and structures, in addition to the building materials permitted by §89-10.B.(2)

§89-15. Modifications to the design standard requirements.

These design standards of the Downtown Core Overlay are considered the minimum standards that the applicant shall adhere to. All of the design standards of the Downtown Core Overlay are vital if the traditional neighborhood development atmosphere of the downtown is to be achieved. It is the intent of this section to encourage flexibility, economy, ingenuity, and sustainability in the development of tracts within this the Downtown Core Overlay. To this end, the applicant may request a modification of the minimum design criteria of this Chapter if such modification will enable the design of a development that still achieves the purpose and objectives expressed in this Chapter. Modifications shall be presented with a submission to the DCDB and shall be reviewed pursuant to the procedures of §89-8.C. This modification process shall not permit modification to the requirements of Chapter 225, Zoning, or Chapter 185, Subdivision and Land Development. Relief from those respective Chapters shall be requested by the applicant and reviewed by the Township in compliance with the requirements of those Chapters.

SECTION 2: All ordinances or parts of ordinances inconsistent herewith are hereby repealed to the extent of such inconsistency.

SECTION 3: If any section, subsection, sentence, or clause of this ordinance is held, for any reason, to be invalid, such decision or decisions shall not affect the validity of the remaining portions of this ordinance.

SECTION 4: The Board of Supervisors finds that this ordinance is consistent with the overall goals of the Derry Township Comprehensive Plan.

ORDAINED AND ENACTED into law this 28th day of March, 2017 to become effective five days from the date hereof.

BOARD OF SUPERVISORS
TOWNSHIP OF DERRY
DAUPHIN COUNTY, PENNSYLVANIA

ATTEST

BY: 
Secretary

BY: 
Chairman

(Seal)

APPENDIX A

EXISTING ARCHITECTURE OF DOWNTOWN HERSHEY

Existing Downtown Core Design Elements

Background Information:

The photos on the left depict the buildings that are part of the redevelopment of the first block of West Chocolate Avenue, between Cocoa Avenue and Linden Road. The Hershey Press Building (top photo) was renovated beginning in 2004 and is now used as a mixed-use building containing restaurants and office uses. The renovation restored the building to its original 1920's appearance. The parking garage structure (center photo) was constructed as part of the Hershey Intermodal Center beginning in 2004, and the Hershey Story Museum (bottom photo) was constructed to the west of the Press Building and opened in 2009.

Design Elements:

- All three buildings contain red brick construction in traditional bond patterns, including basket weave designs that have been incorporated into each of the structures. The basket weave elements provide architectural continuity between the three structures and the variations in bond patterns provide aesthetic interest to each building.
- The Hershey Story Museum has been designed with vertical articulation and cornices to prevent a long, flat building face along Chocolate Avenue.
- Similar stone cornices and quoins have been constructed on the Press Building that break up the otherwise flat façade of the architecture. These features have been constructed to be consistent with the 1920's design of the building.
- Predominant orientation of the buildings is toward West Chocolate Avenue, with the Hershey Story Museum providing primary access off of the public sidewalk. The entrance to the building is protrudes as part of the articulation to provide a well-defined building entry.
- The façade of the parking garage is similar to surrounding buildings, and the structure is inset behind commercial uses.
- The Press Building contains outdoor seating along West Chocolate Avenue, with patio walls matching the stone trim elements on the building.



Existing Downtown Core Design Elements

Many of the early buildings constructed in Downtown Hershey during the 1900s-1930s contain a variety of stone materials. The most widely used stone was limestone, which is still prominent on many of the older buildings that remain today. These buildings include the former Chocolate Factory (now The Hershey Company's Corporate Offices), the "Community Building", and the First United Methodist Church building (all pictured right). Other stone material was used, including marble, which was the prominent material used on the façade of the Hershey Trust bank building. All buildings featured to the right contain stone that is laid in an ashlar pattern and is therefore required by this Chapter for buildings proposing similar stone materials.

- The Hershey Company Corporate Offices, 19 E. Chocolate Ave. (Lower Left)
- The Hershey Trust Bank Building, 1 E. Chocolate Ave. (Upper Right)
- Community Building (Hershey Theatre), 14. E. Chocolate Ave. (Center Right)
- First United Methodist Church, 64 W. Chocolate Ave. (Lower Right)



Existing Downtown Core Design Elements



Design Elements on West Chocolate Avenue:

Many of the properties in the District along West Chocolate Avenue, beginning West of Linden Road, contain narrower property widths averaging 40 to 50 feet. As a result, consistent building massing can be found in these areas. Common design elements on the buildings along West Chocolate Avenue include brick, stone or siding materials, hipped or gabled roofs, dormered windows, and roof-covered front porches.

A mix of uses can be found on the smaller properties along West Chocolate Avenue, including commercial offices, retail and other personal services on the first floor, and apartment dwellings on the upper floors. Other buildings contain all dwellings, mostly in an apartment style configuration. The majority of parking sits behind the structure and is accessed from rear alley locations. Lastly, numerous properties contain masonry wall construction, as seen in the upper photo on the left, to define courtyard entry to their property. Like numerous buildings in the downtown, limestone is a commonly used material for these wall features.



Existing Downtown Core Design Elements

Design Elements on West Caracas Avenue:

Like West Chocolate Avenue, many of the properties along West Caracas Avenue contain property widths of 40 to 50 feet. As a result, similar building massing can also be found in these areas. Similar design elements can be found along West Caracas Avenue, including brick, stone or siding materials, hipped or gabled roofs, dormered windows, and roof-covered front porches.

A mix of residential uses exist in this part of the District, including single-family detached, duplex, and apartment type dwellings. Commercial services, many longstanding uses in the community, can be found mixed in with the residential uses. With this area containing good walkability, additional commercial services could be well supported by the community. Most properties also contain parking and alley access to the rear of the lots.



APPENDIX B

DOWNTOWN STANDARDS FOR IMPROVEMENTS IN THE PUBLIC REALM

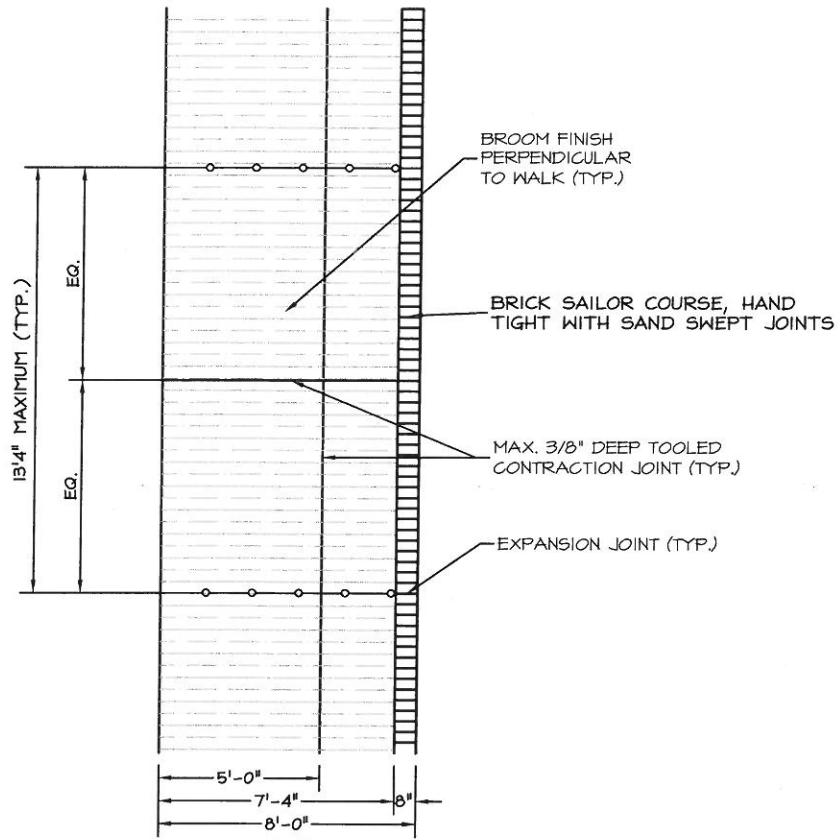

PLAN

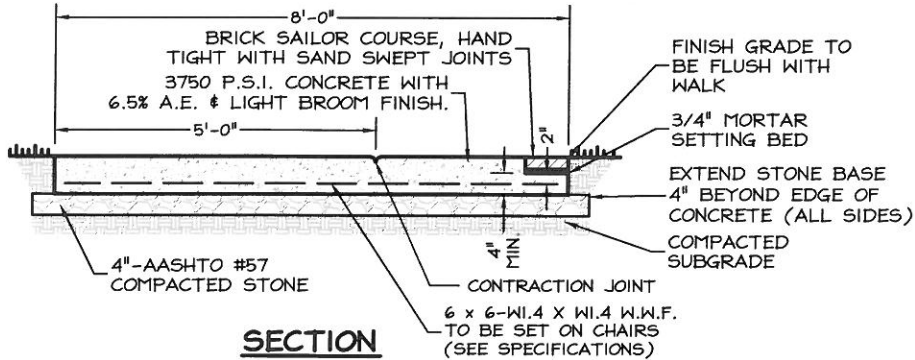

SECTION

**CONCRETE WALK WITH
UNIT PAVER EDGE**
NOT TO SCALE

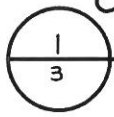

DERCK & EDSON
CAMPUSES • DOWNTOWNS • ATHLETICS
33 SOUTH BROAD STREET LITITZ, PA 17543
101 NORTH ALLEGHENY STREET BELLEFONTE, PA 16823
WWW.DERCKANEDSON.COM (717) 626-2054

CONSTRUCTION DETAILS
SIDEWALK REPLACEMENT OPTIONS
100 BLOCK W. CHOCOLATE AVE.
DERRY TOWNSHIP
DERRY TOWNSHIP, DAUPHIN COUNTY, PA

SCALE: AS SHOWN
DATE: 05/26/16
DWG BY: MAL
PROJ#: 150070

REF. SHEET #:
N/A

GRID #:
N/A

SPEC SECT PAR#:
N/A

OPTION 1

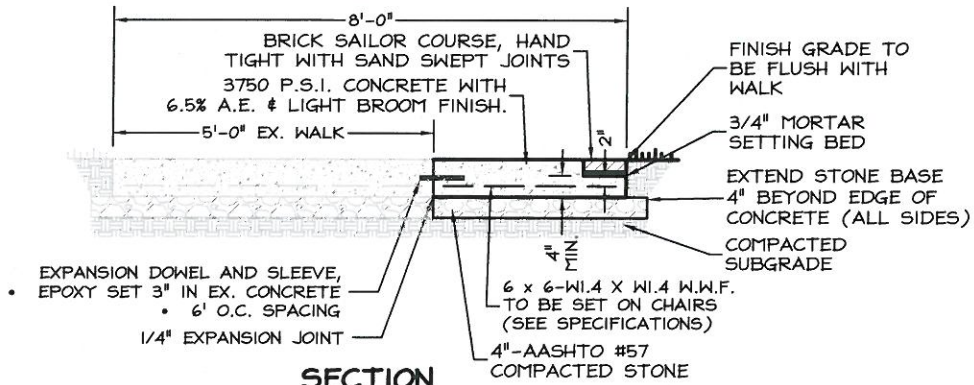
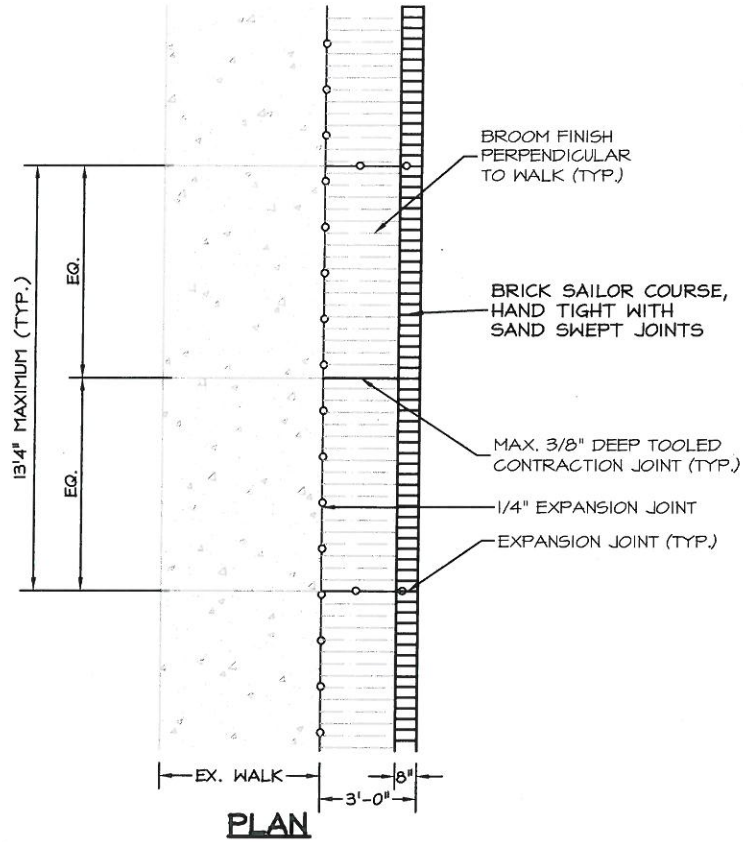

**CONCRETE WALK WITH
UNIT PAVER EDGE**

NOT TO SCALE

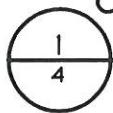

DERCK & EDSON

CAMPUSES • DOWNTOWNS • ATHLETICS

33 SOUTH BROAD STREET LITITZ, PA 17543
101 NORTH ALLEGHENY STREET BELLEFONTE, PA 16823
WWW.DERCKANEDSON.COM (717) 626-2054

**CONSTRUCTION DETAILS
SIDEWALK REPLACEMENT OPTIONS**

100 BLOCK W. CHOCOLATE AVE.
DERRY TOWNSHIP
DERRY TOWNSHIP, DAUPHIN COUNTY, PA

SCALE: AS SHOWN
DATE: 05/26/16
DWG BY: MAL
PROJ#: 150070

REF. SHEET #:
N/A

GRID #:
N/A

SPEC SECT PAR#:
N/A

OPTION 2

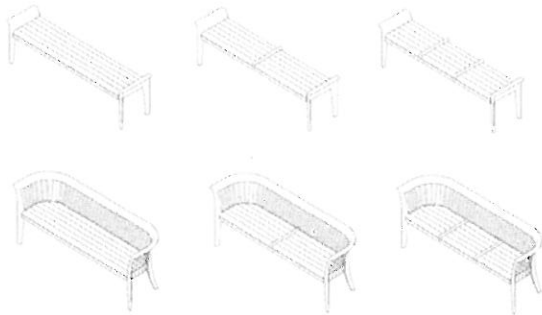

Bench options

Included components:

- Anchoring hardware is included when bench is specified as Surface Mount or Embedded

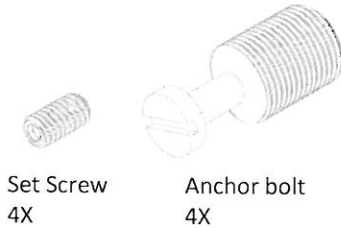

Set Screw
4X

Anchor bolt
4X

Tools Required, for Surface Mount or Embedded mounting option

- Safety glasses
- Bench ships fully assembled, optional dividers are factory installed.
- Slotted screwdriver
- Chemical anchoring adhesive (Hilti HIT RE 500 or equivalent)
- Hammer drill with masonry bits
- Blanket or other padded material, for protecting powdercoat finish

For Surface Mount Option:

- 1/8" hex key
- (4) Stainless steel drop-in screw anchors for 5/8-11 thread, minimum 7/8" thread length, and setting tool

ASSEMBLE WITH CARE! Pangard II® Polyester Powdercoat is a strong, long-lasting finish. To protect this finish during assembly, place unwrapped powdercoated parts on packaging foam or other non-marring surface. Do not place or slide powdercoated parts on concrete or other hard or textured surface – this will damage the finish causing rust to occur. Use touch-up paint on any gouges in the finish caused by assembly tools.

PROCEDURE FOR INSTALLATION:

1. Prepare proper concrete slab as required.
2. Freestanding bench ships with glides installed. Bench can be set in place.

Note: DO NOT DRAG bench across concrete or other rough surfaces. This could damage the powdercoat finish.

For SURFACE MOUNT or EMBEDDED bench:

1. For surface mount or embedded option, tip bench onto protective material and remove glides using a slotted screwdriver.
2. Thread surface mount bolt into casting leg (4) places, as shown in Fig. 1.2.
3. Set bench in place and mark hole locations.
4. Move bench and drill holes according to diameter and depth required by anchoring adhesive manufacturer or drop-in screw anchor manufacturer. Clear holes of debris.

For EMBEDDED bench:

1. Fill holes with chemical anchoring adhesive. Set bench in place.

For SURFACE MOUNT bench:

1. Remove surface mount bolts from castings. If using chemical anchoring adhesive, install in holes as shown in Fig. 1.5. If using drop-in anchors, install according to manufacturer's recommendations and thread in surface mount bolts.
2. After proper curing time, set bench over surface mount bolts and install set screws as shown in Fig. 1.6.

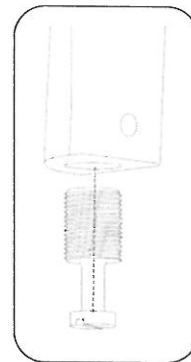

Fig. 1.2

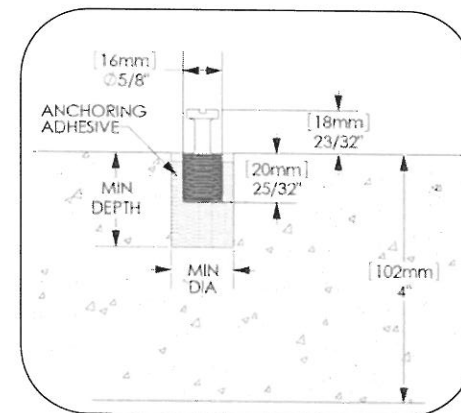

Fig. 1.5

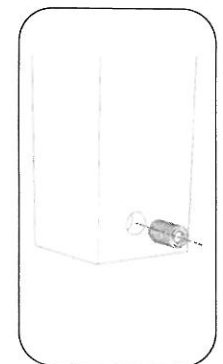
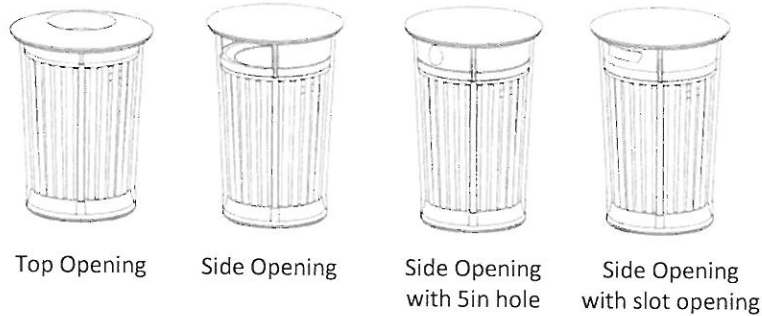
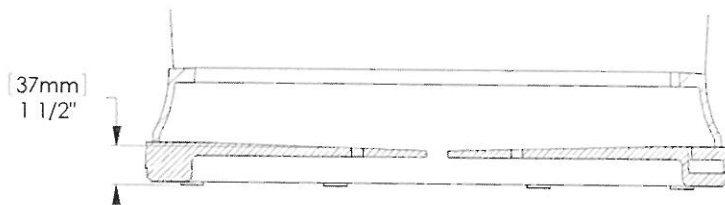

Fig. 1.6



Tools Required

- Safety glasses
- **CAUTION!** This litter receptacle is heavy. To avoid injury or damage to the finish, we recommend using a two-wheeled hand truck to move this item.
- Litter receptacle ships fully assembled with freestanding glides.
- Anchoring hardware for surface mount option. Two anchors, 3/8" diameter or less, are required per unit. The base casting adds 1-1/2" to the anchor length. The installer is responsible for anchoring hardware suitable for site conditions. Corrosion resistant anchors are recommended.



Base casting section view

ASSEMBLE WITH CARE! Pangard II® Polyester Powdercoat is a strong, long-lasting finish. To protect this finish during assembly, place unwrapped powdercoated parts on packaging foam or other non-marring surface. Do not place or slide powdercoated parts on concrete or other hard or textured surface – this will damage the finish causing rust to occur. Use touch-up paint on any gouges in the finish caused by assembly tools.

Date: September 2011
U.S. Patent No. D643,986; D643,987

PROCEDURE FOR INSTALLATION:

FOR SURFACE MOUNTED LITTER RECEPTACLE:

Note: Unit can be surface mounted with freestanding glides installed.

1. Place the unit in the desired position. Open the door to check clearance.
2. Remove the liner and mark anchor locations through the holes in the base.
3. Move the unit to allow access for drilling holes.
4. Drill holes at marked locations according to anchor manufacturer's specification.
5. Complete the anchor installation according to the anchor manufacturer's instructions.

FOR LOCK OPTION:

- Litter receptacle locks are keyed alike. Each receptacle is shipped with two keys. The key can be removed in both the locked and unlocked position.

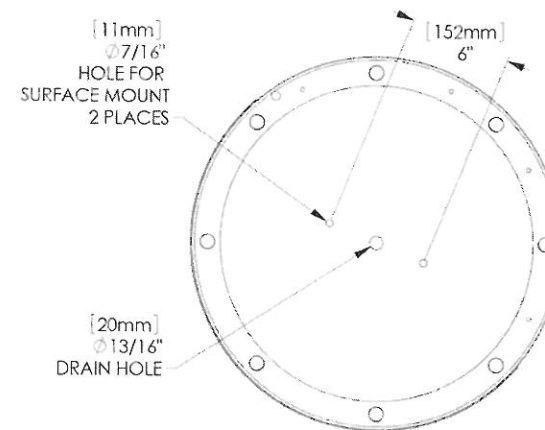

Base casting bottom view



Bike Rack

Included components



1x - Frame



1x - Cover plate



1x - Set screw
1/4-20 x 1"



Embedded option:
2x - Threaded rod
5/8-11 x 3-1/2"
with thread patch

Tools Required

- Unit ships assembled
- 1/8" hex key
- 3/16" hex key
- Hammer drill with masonry bits
- For embedded mount option: chemical anchoring adhesive (Hilti HIT RE 500 or equivalent)
- For surface mount option: stainless steel anchoring hardware, (2) required per unit (not included). Landscape Forms, Inc. recommends maximum 1/2" dia bolt, with a minimum embedded depth of 3" (see Fig. 5. for bolt clearances).

WARNING! Unit must be anchored.

HANDLE WITH CARE! Emerson's finish can be scuffed by contact with tools, concrete, or other abrasive surfaces. Protect the finish from damage during installation. Use touch-up paint to repair any powder coat finish abrasions.

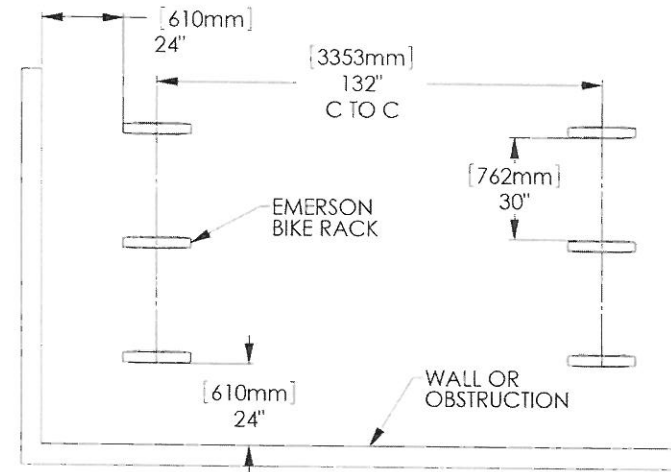

Fig. 1. - Recommended spacing, according to Association of Pedestrian and Bicycle Professionals (APBP)

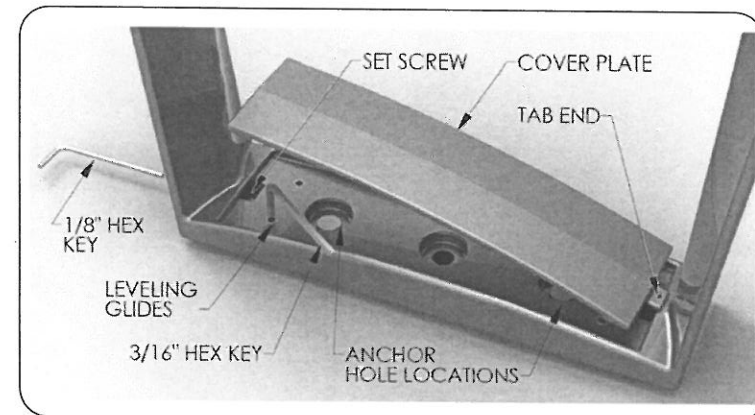

Fig. 2. - Component detail

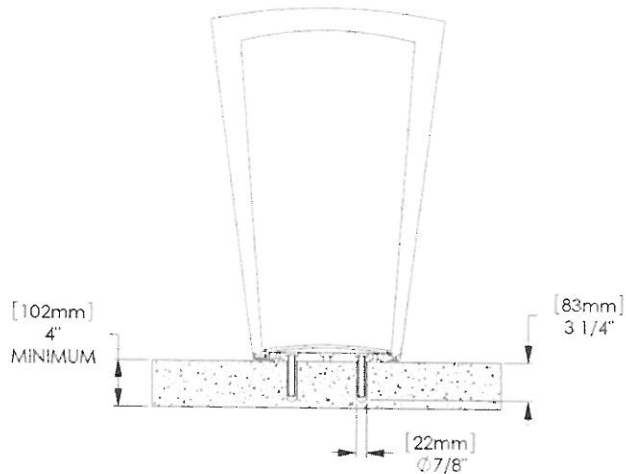

Fig. 3. – Hole size for embedded bike rack

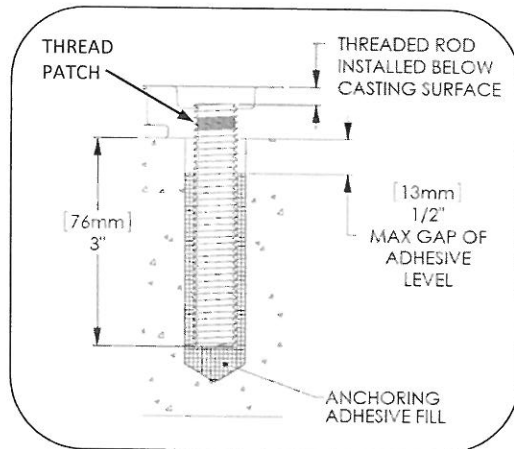

Fig. 4. – Install threaded rod

INSTALLATION PROCEDURE:

WARNING! Unit must be anchored.

1. Set bike rack in position. Using 3/16" hex key, adjust leveling glides until unit is plumb.
2. Mark hole locations. See Fig. 1 for recommended spacing.
3. Move bike rack and drill holes. Clear debris from holes.

FOR EMBEDDED MOUNT:

1. Thread anchor rods with thread patch into bike rack as shown in Fig. 4.
2. Fill holes with adhesive to level shown in Fig. 4.
3. Set unit in place and wipe away excess adhesive.
4. After adhesive has fully cured to manufacturer's recommendation, turn all four leveling glides equally until tight to remove any excess movement of the bike rack.

FOR SURFACE MOUNT:

1. Set unit in place and install anchor bolts (not supplied by Landscape Forms) according to anchor manufacturer's instructions.
2. Turn all four leveling glides equally until tight to remove any excess movement of the bike rack.

FOR COVER PLATE INSTALLATION:

1. Install cover plate by inserting tab end into casting frame.
2. Using 1/8" hex key, install 1/4-20 set screw in opposite end of cover plate, through the casting frame.
3. Tighten set screw until cover plate is secure. **Warning!** Do not over tighten the set screw, which can cause the cover plate to deform.

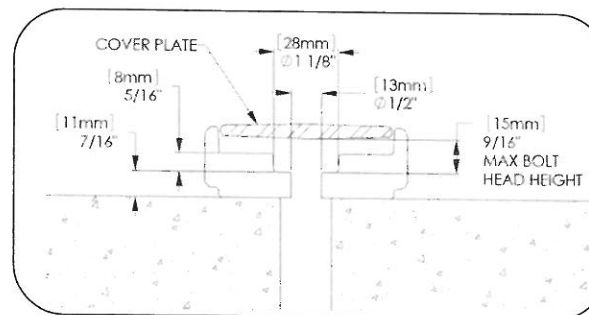
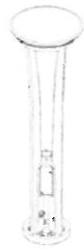

Fig. 5. – Anchor hole clearance for surface mount



Surface Mount

Included hardware



1x – Lightpole assembly



4x – Cabinet cover



1x – LED driver



1x – Cabinet dome cover



1x – Cabinet dome retainer bar



4x – Cabinet cover screw

Tools Required

- Safety glasses
- Screwdrivers
- Wiring tools and connectors
- Anchoring hardware – (4) Ø3/8 (maximum) x 3-1/2" length stainless steel anchors. Landscape Forms recommends Power bolts or drop-in wedge anchors
- Hammer drill
- 3/16" hex key

LIGHTING LAYOUT RECOMMENDATIONS:

Although light pole spacing is the responsibility of others, the following can be used to help determine appropriate spacing:

Hawthorne distribution is an IES Type 4 pattern and meets or exceeds IESNA DG-5 for Park walkways, Class 1 bikeways, Residential sidewalks and Intermediate sidewalks at 25' pole spacing, and Commercial sidewalks at 15' pole spacing. Poles can also be spaced 15' apart on both sides of a 10' path for Public-Way Emergency Egress. Outside of North America, Hawthorne meets CIE-136-2000 for Residential Parks at 25' pole spacing.

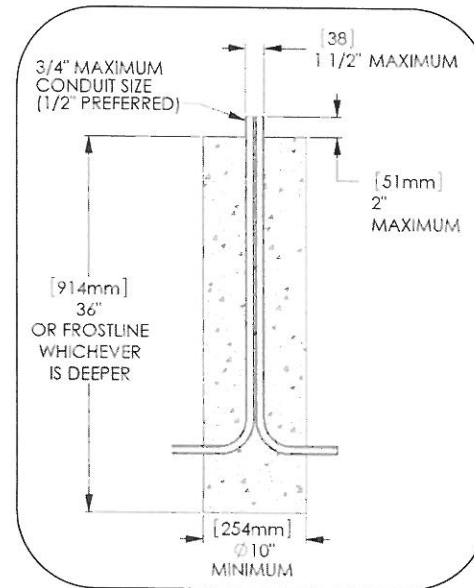

Fig. 1 – Minimum footing recommendation

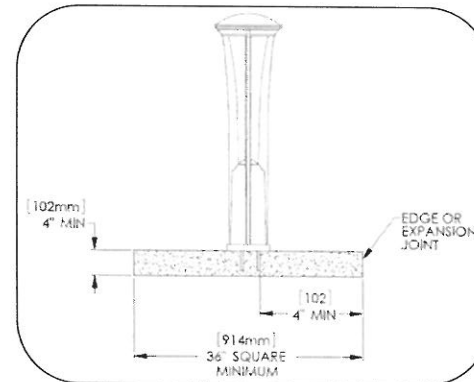

Fig. 2 – Minimum concrete slab size

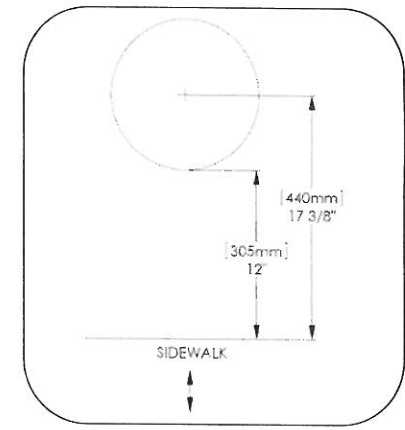

Fig. 3 – Recommended setback from sidewalk

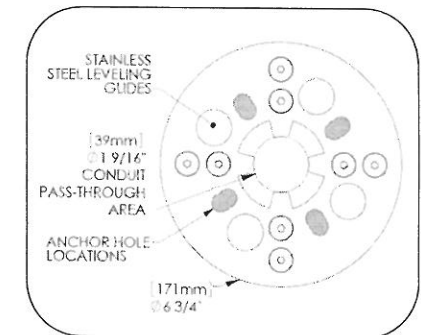

Fig. 4 – Bottom view

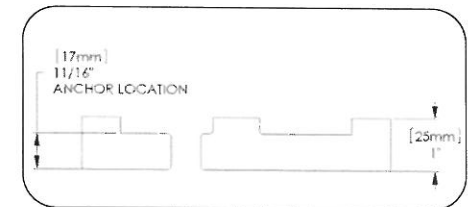

Fig. 5 – Base plate section view

ASSEMBLE WITH CARE! Pangard II® Polyester Powdercoat is a strong, long-lasting finish. To protect this finish during assembly, place unwrapped powdercoated parts on packaging foam or other non-marring surface. Do not place or slide powdercoated parts on concrete or other hard or textured surface – this will damage the finish causing rust to occur. Use touch-up paint on any gouges in the finish caused by assembly tools.

Landscape Forms is not responsible for site preparation and footings. Footing recommendations are included in these instructions.

INSTALLATION PROCEDURE FOR LIGHT POLE:

1. Prepare footing as required by local codes, see Fig. 1, Fig. 2 and Fig. 3 for recommendations.
2. Set pathway light in position over conduit, ensuring that base sits flat on concrete.
3. Mark four anchor hole locations and move light unit.
4. Drill holes according to anchor size and depth. Clear holes of debris.
5. Set unit in place and install anchors according to anchor manufacturer's recommendations.
6. Using 3/16" hex key, adjust leveling glides until unit is plumb.

PROCEDURE FOR INSTALLING CABINET COVERS:

1. Set retainer bar in the casting pocket.
2. Install cabinet covers as shown, ensuring bottom tab of cover rests in the groove in base casting. Repeat for remaining three covers.
3. Install cabinet dome cover by threading into the retainer bar until tight.

PROCEDURE FOR WIRING HAWTHORNE:

The Hawthorne pathway light is assembled at the factory. The light cartridge is mounted into the head of the pole and will not need to be removed during installation. The LED cartridge is wired to the driver (located in the cabinet) at the factory.

The following schematic is to be used to connect the unit to line voltage. It is the responsibility of the installer to make sure that all connections are made in accordance with the NEC and local building codes. Connection hardware not included.

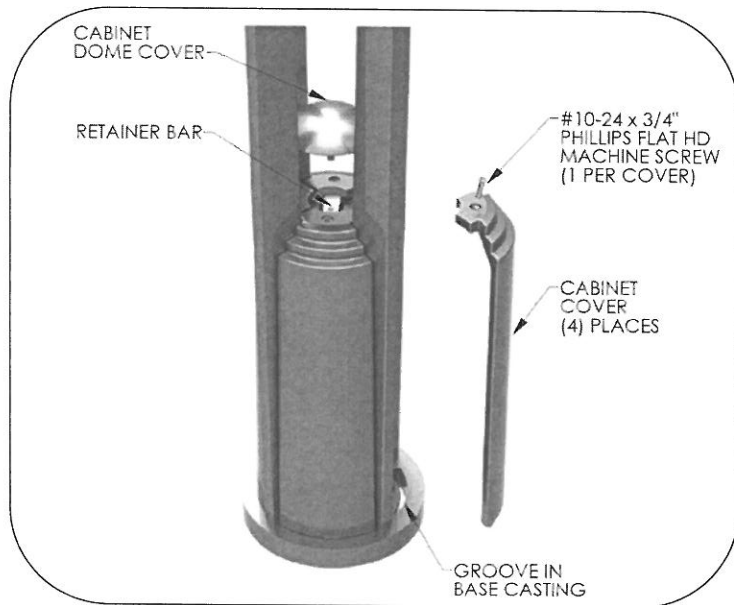

Fig. 6 – Remove access panel

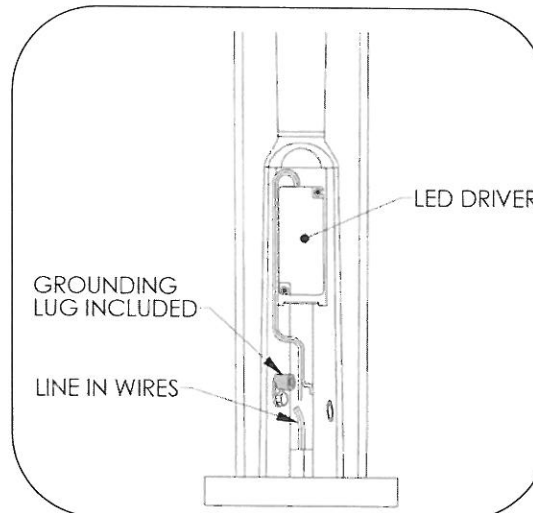

Fig. 7 – Access panel removed

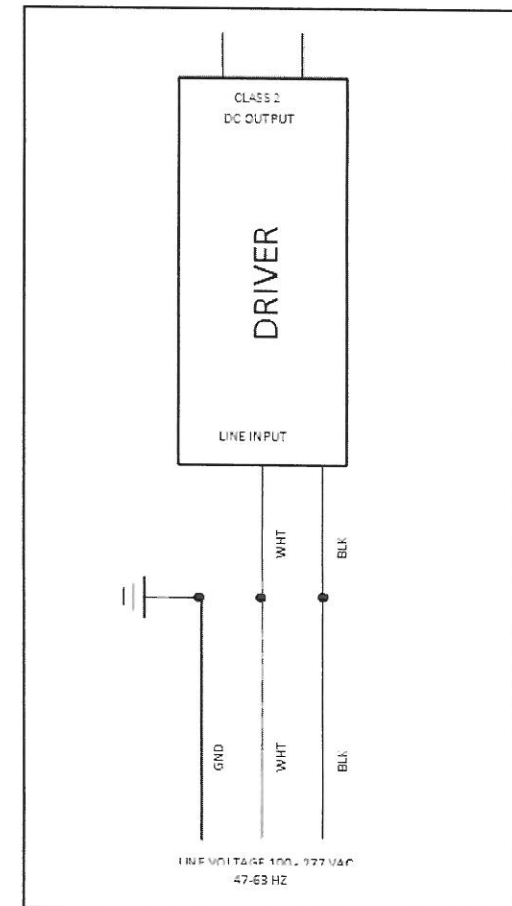

Fig. 8 – Hawthorne wiring schematic